

# REINOGRIP Repair Coupler

## Mounting instructions 1/2

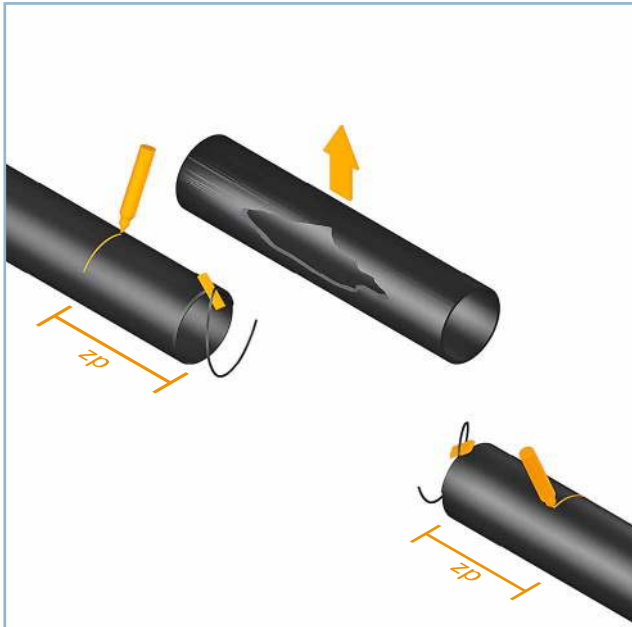

1. Remove damaged pipe section.
2. Mark insertion depth (z<sub>p</sub>).
3. Chamfer both pipe ends.

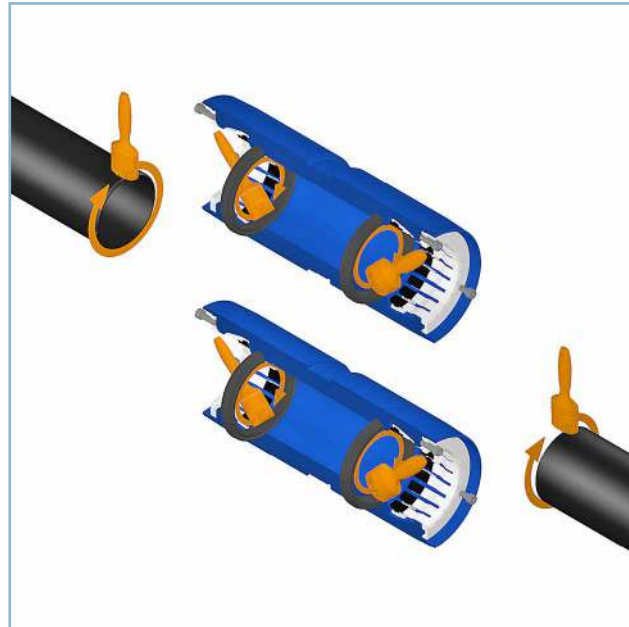

4. Apply lubricant both to inside gaskets and chamfered pipe ends. In case of drinking water pipelines use lubricant with DVGW approval only.

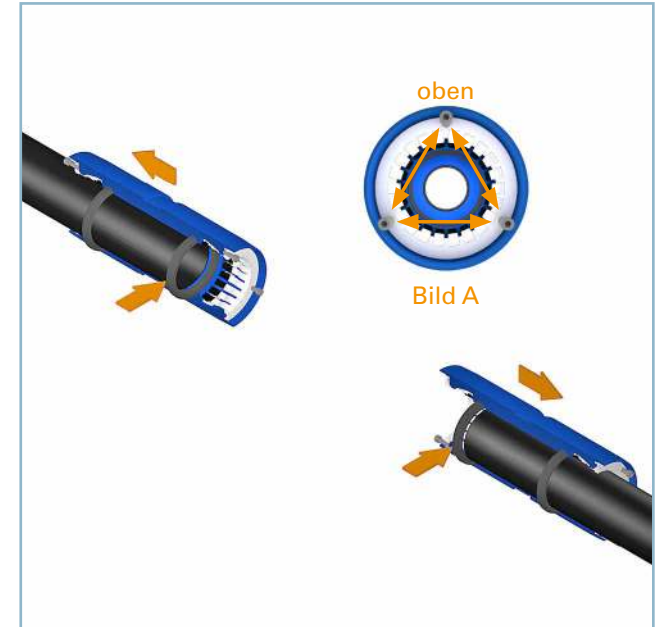

5. Push repair coupler onto each pipe end up to second gasket. Pay attention to correct position of screws. (Picture A).

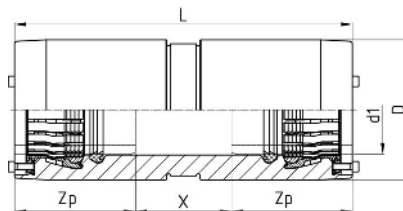

### Insertion depths

Diameter (d1)	90 mm	110 mm	125 mm	160 mm	180 mm	200 mm	225 mm
Insertion depth (z <sub>p</sub> )	150 mm	152 mm	156 mm	164 mm	194 mm	198 mm	203 mm

# REINOGRIP Repair Coupler

## Mounting instructions 2/2

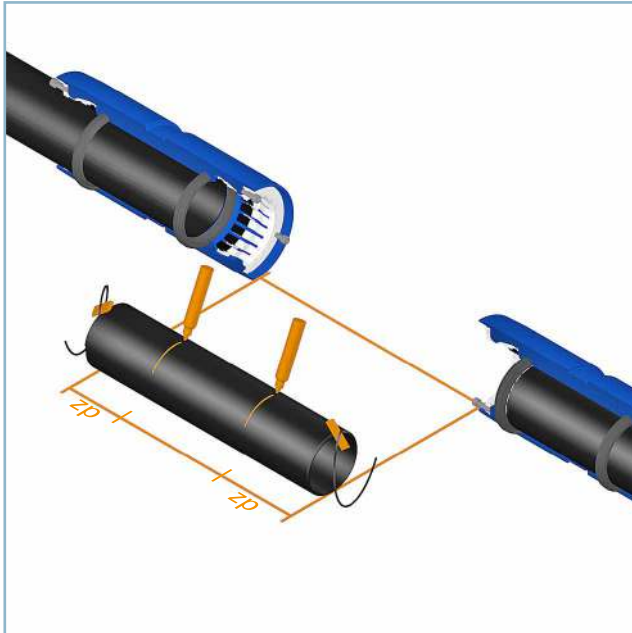

6. Measure distance between repair couplers.
7. Take this measurement for the new pipe section.
8. Mark insertion depth (zp).
9. Chamfer both pipe ends.



10. Place new pipe section between two couplers.
11. Push repair couplers up to respective insertion depths.

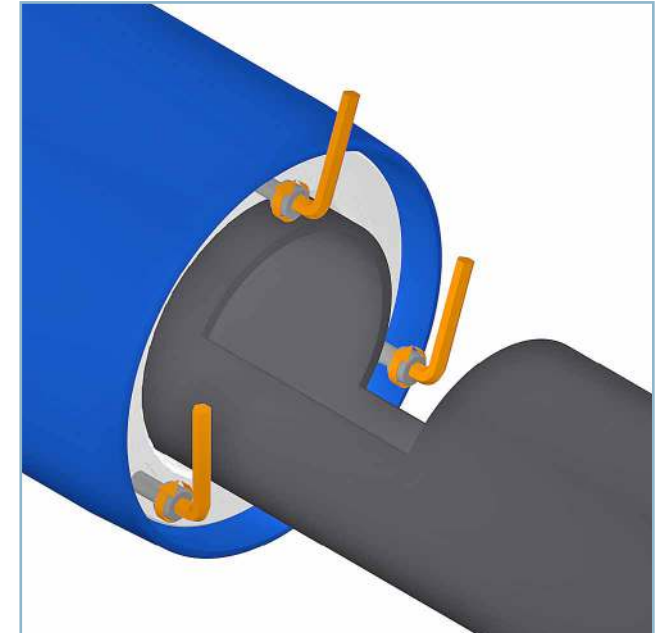

12. Tighten all screws by turns in three steps until the white ring is flush with sleeve end.

Mounting aid  
(optional)



Lubricant for  
plastic pipes



Chamfering  
equipment



Laying equipment  
for large  
dimensions



[www.youtube.de/  
ReinertRitzGmbH](https://www.youtube.de/ReinertRitzGmbH)