

## Rohrendkappe, kurz

- kurzes Schweißende

optional: mit Rohr verlängert

## End cap, short form

- short welding end

optional: extended with pipe

EK2 - 2021 #1

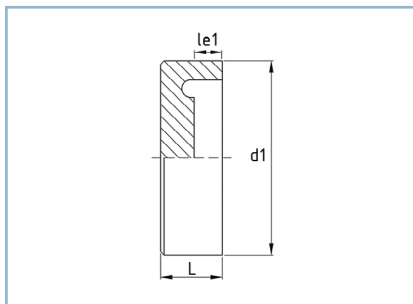

DVGW:  
DV-8606BT0423 (Ø 75 mm - Ø 225 mm)  
DV-8611BT0424 (Ø 250 mm - Ø 630 mm)

SDR ≥ 41 33 26 21 17,6 17 13,6 11 9 7,4 6 ≤ 5

d <sub>1</sub>	l <sub>e1</sub>	Gewicht weight			
		L	kg	PE 100	PP-R
50	17	25	0,02		
63	15	25	0,04		
75	14	25	0,1		
90	16	30	0,1		
110	19	35	0,2		
125	17	35	0,3		
140	15	35	0,3		
160	17	40	0,5		
180	19	45	0,7		
200	16	45	1		
225	17	50	1,4		
250	19	55	1,9		
280	19	60	2,7		
315	19	65	3,7		
355	19	70	5,2		
400	17	75	7,4		
450	20	85	10,5		
500	18	90	14,2		
560	19	100	20		
630	19	110	28,3		
710	26	130	33,5		
800	23	140	47,5		
900	28	160	66		
1000	28	175	106		
1200	29	205	184		

## Rohrendkappe, kurz

- kurzes Schweißende

optional: mit Rohr verlängert

## End cap, short form

- short welding end

optional: extended with pipe

EK2 - 2021 #1

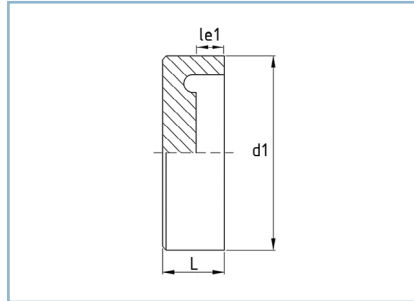
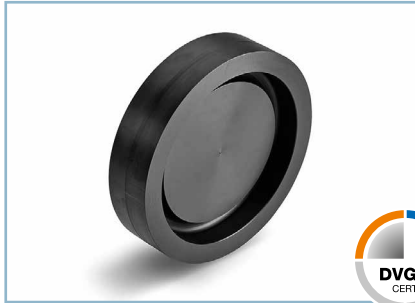

DVGW:  
DV-8606BT0423 (Ø 75 mm - Ø 225 mm)  
DV-8611BT0424 (Ø 250 mm - Ø 630 mm)

SDR ≥ 41 33 26 21 17,6 17 13,6 **11** 9 7,4 6 ≤ 5

d <sub>1</sub>	l <sub>e1</sub>	Gewicht weight			
		L	kg	PE 100	PP-R
50	15	25	0,02		
63	19	30	0,1		
75	17	30	0,1		
90	14	30	0,1		
110	16	35	0,2		
125	18	40	0,3		
140	16	40	0,4		
160	17	45	0,7		
180	14	45	0,9		
200	15	50	1,2		
225	16	55	1,7		
250	17	60	2,3		
280	17	65	3,2		
315	16	70	4,4		
355	19	80	6,4		
400	16	85	8,9		
450	17	95	12,7		
500	19	105	17,4		
560	19	115	24,1		
630	17	125	33,9		
710	28	150	47		
800	27	165	67		
900	30	185	95		
1000	38	210	131		
1200	34	240	224		