

Sonderflansch, PN 10 gebohrt

- inklusive EPDM O-Ring
- kunststoffbeschichteter Stahlflansch
- langes Schweißende, für E-Muffen-Schweißung geeignet

optional: Flansche aus Edelstahl; Flansche aus verzinktem Stahl; flachdichtend ohne Nut und ohne O-Ring; PN 25 gebohrt; mit Langloch

Anwendung: direkter Anschluss an Armaturen ohne Reduzierung der Nennweite (DN)

SF reduced flange, PN 10 drilled

- with EPDM O-ring
- steel backing rings, plastic coated
- long welding end, for the use of electrofusion sockets

optional: stainless steel backing rings; hot dipped galvanized backing rings; flat sealing surface without flute or o-ring; PN 25 drilled; with slotted holes

application: for direct connection to valves according to nominal diameter (DN)

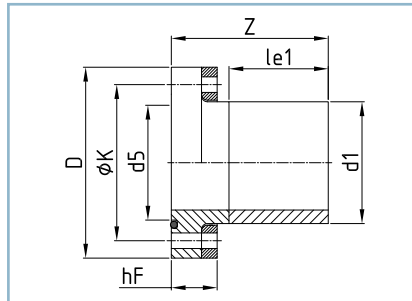

Flansch/flange: DIN EN 1092-1, PN 10

DVGW für PE-Formteil / for PE part:
DV-8606BT0423 (Ø 75 mm - Ø 225 mm)
DV-8611BT0424 (Ø 250 mm - Ø 630 mm)

Toleranzen/tolerance (S./p. 11):

Z, l_{e1} --> Tab./tab. 1

SF - 2019 #1

SDR	≥ 41	33	26	21	17,6	17	13,6	11	9	7,4	6	≤ 5
-----	------	----	----	----	------	----	------	----	---	-----	---	-----

DN	d_1	d_5	l_{e1}	ØK	n x ØL	Schrauben Bolts	D	h_F		Z		Gewicht weight kg	
								SDR 17	SDR 11	SDR 17	SDR 11	SDR 17	SDR 11
65	90	90	200	145	8x18	M16	185	36	36	255	255	3	3,2
80	110	105	200	160	8x18	M16	200	48	48	300	300	3,9	4,2
100	140	132	200	180	8x18	M16	220	38	43	260	260	3,3	4,7
125	160	157	200	210	8x18	M16	250	38	43	265	270	5	5,8
125	180	157	200	210	8x18	M16	250	38	43	315	315	6,2	6,5
150	200	183	200	240	8x23	M20	285	43	48	260	265	6,4	7,4
200	250	235	200	295	8x23	M20	340	43	53	260	270	6,6	10,8
250	315	291	200	350	12x23	M20	395	49	54	310	320	13,2	15,6
300	355	330	200	400	12x23	M20	445	55	65	270	280	15,1	19,0
350	400	393	300	460	16x23	M20	505	64	74	375	385	24,8	31,2
400	450	445	300	515	16x27	M24	565	66	81	375	390	31,6	40,2
400	500	445	300	515	16x27	M24	565	66	81	570	590	42,5	56,3
400	450	490	300	565	20x27	M24	615	74	88	375	400	49,3	38,4
500	560	546	300	620	20x27	M24	670	76	96	385	405	46,4	60,7
500	630	546	300	620	20x27	M24	670	76	96	590	610	64,8	87,3
600	710	643	500	725	20x30	M27	780	86	106	800	820	106	142,0
700	800	750	500	840	24x30	M27	895	96	116	800	820	130	177,0
800	900	870	500	950	24x33	M30	1015	105	130	820	840	176	238,0
900	1000	960	500	1050	28x33	M30	1115	114	134	840	860	232	296,0
1000	1200	1060	500	1160	28x36	M33	1230	129	154	930	990	344	472,0

In unserem Downloadportal auf www.reinert-ritz.de finden Sie unsere Broschüre zum Thema „Flanschverbindungen“ mit vielen hilfreichen Informationen.

In our download portal at www.reinert-ritz.de, you can find our brochure on „flanged connections“ with a lot of useful information.



Ausführung abhängig von der SDR-Klasse und DN/ d_1 -Kombination
type depending on the SDR-class and on the combination of DN/ d_1

Weitere Ausführungen (z.B. Größen, Gradzahlen, Werkstoffe u. Farben) oder Anwendungen (z.B. Gas) auf Anfrage
More designs (e.g. sizes, numbers of degrees, materials & colors) or applications (e.g. gas) on request



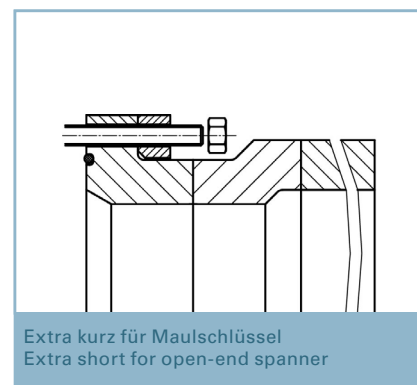
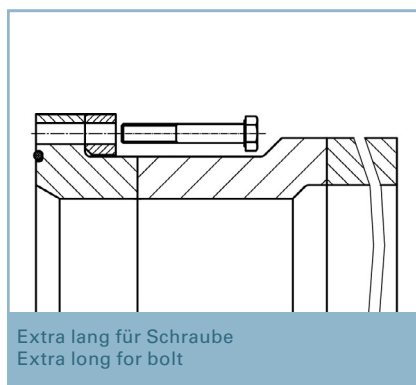
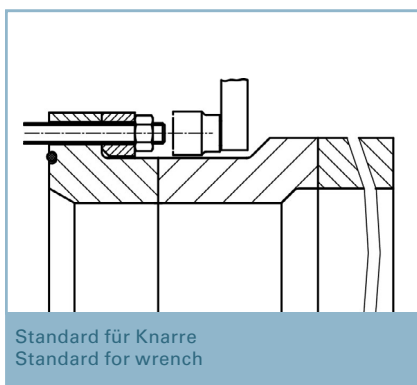

SDR 11

DN	d ₁	Optionen - Options	
		extra lang/extra long	extra kurz/extra short
		Z	Z
500	630	860	560
600	710	920	770
700	800	910	740
800	900	960	730
900	1000	970	760
1000	1200	1080	900

SDR 17

DN	d ₁	Optionen - Options	
		extra lang/extra long	extra kurz/extra short
		Z	Z
500	630	860	560
600	710	920	770
700	800	910	740
800	900	960	730
900	1000	970	760
1000	1200	1030	850

Ausführung abhängig von der SDR-Klasse und DN/d₁-Kombination
type depending on the SDR-class and on the combination of DN/d₁

Sonderflansch, PN 16 gebohrt

- inklusive EPDM O-Ring
- kunststoffbeschichteter Stahlflansch
- langes Schweißende, für E-Muffen-Schweißung geeignet

optional: Flansche aus Edelstahl; Flansche aus verzinktem Stahl; flachdichtend ohne Nut und ohne O-Ring; PN 25 gebohrt; mit Langloch

Anwendung: direkter Anschluss an Armaturen ohne Reduzierung der Nennweite (DN)

SF reduced flange, PN 16 drilled

- with EPDM O-ring
- steel backing rings, plastic coated
- long welding end, for the use of electrofusion sockets

optional: stainless steel backing rings; hot dipped galvanized backing rings; flat sealing surface without flute or o-ring; PN 25 drilled; with slotted holes

application: for direct connection to valves according to nominal diameter (DN)

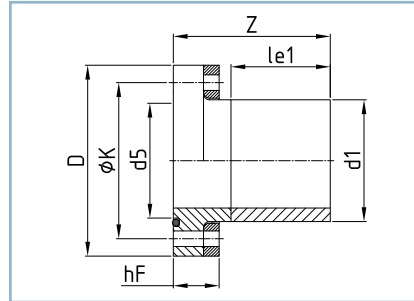

Flansch/flange: DIN EN 1092-1, PN 16

DVGW für PE-Formteil / for PE part:
DV-8606BT0423 (Ø 75 mm - Ø 225 mm)
DV-8611BT0424 (Ø 250 mm - Ø 630 mm)

Toleranzen/tolerance (S./p. 11):

Z, l_{e1} --> Tab./tab. 1

SF - 2019 #1

SDR	≥ 41	33	26	21	17,6	17	13,6	11	9	7,4	6	≤ 5
-----	------	----	----	----	------	----	------	----	---	-----	---	-----

DN	d_1	d_5	l_{e1}	ØK	n x ØL	Schrauben Bolts	D	h_F		Z		Gewicht weight kg	
								SDR 17	SDR 11	SDR 17	SDR 11	SDR 17	SDR 11
65	90	90	200	145	8x18	M16	185	36	36	250	255	3	3,2
80	110	105	200	160	8x18	M16	200	48	48	300	300	3,9	4,2
100	140	132	200	180	8x18	M16	220	38	43	255	260	3,3	4,7
125	160	157	200	210	8x18	M16	250	38	43	265	270	5	5,8
125	180	157	200	210	8x18	M16	250	38	43	310	315	6,2	6,5
150	200	183	200	240	8x23	M20	285	43	48	260	265	6,4	7,4
200	250	240	200	295	12x22	M20	340	45	55	260	270	9,2	11,1
250	315	291	200	355	12x26	M24	405	54	59	320	330	15,1	18,5
300	355	335	200	410	12x26	M24	460	61	71	270	280	19,6	23,6
350	400	394	300	470	16x26	M24	520	69	79	375	385	30,3	36,7
400	450	445	300	525	16x30	M27	580	72	87	375	390	38,5	47,3
400	500	445	300	525	16x30	M27	580	72	87	565	590	48,8	63,5
500	560	553	300	650	20x33	M30	715	83	103	385	405	66,1	80,8
500	630	553	300	650	20x33	M30	715	83	103	610	630	84,2	109,0
600	710	650	500	770	20x36	M33	840	92	112	810	840	128	168,0
700	800	750	500	840	24x36	M33	910	105	125	830	860	156	205,0
800	900	850	500	950	24x39	M36	1025	116	131	850	890	211	280,0
900	1000	930	500	1050	28x39	M36	1125	126	156	890	920	280	352,0
1000	1200	1050	500	1170	28x42	M39	1225	140	165	950	990	398	518,0

In unserem Downloadportal auf www.reinert-ritz.de finden Sie unsere Broschüre zum Thema „Flanschverbindungen“ mit vielen hilfreichen Informationen.

In our download portal at www.reinert-ritz.de, you can find our brochure on „flanged connections“ with a lot of useful information.



Ausführung abhängig von der SDR-Klasse und DN/ d_1 -Kombination
type depending on the SDR-class and on the combination of DN/ d_1

Weitere Ausführungen (z.B. Größen, Gradzahlen, Werkstoffe u. Farben) oder Anwendungen (z.B. Gas) auf Anfrage
More designs (e.g. sizes, numbers of degrees, materials & colors) or applications (e.g. gas) on request

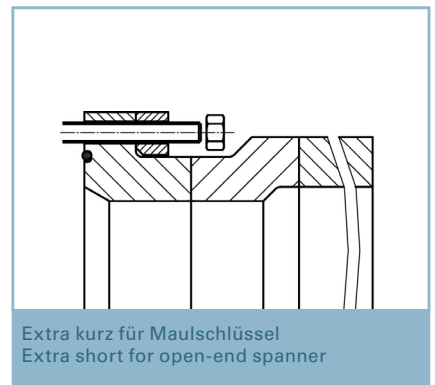
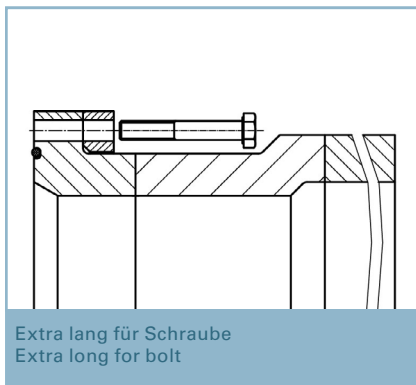
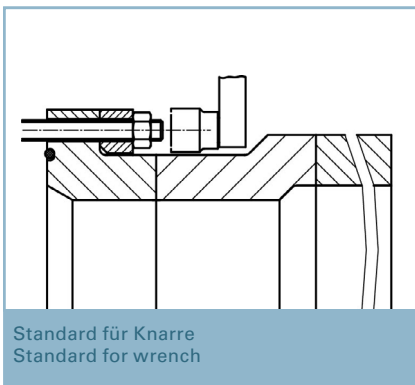

SDR 11

DN	d ₁	Optionen - Options	
		extra lang/extra long	extra kurz/extra short
		Z	Z
500	630	860	560
600	710		790
700	800	990	810
800	900	1030	830
900	1000	1060	850
1000	1200	1130	910

SDR 17

DN	d ₁	Optionen - Options	
		extra lang/extra long	extra kurz/extra short
		Z	Z
500	630	860	560
600	710		790
700	800	990	810
800	900	1030	830
900	1000	1060	850
1000	1200	1090	870

Ausführung abhängig von der SDR-Klasse und DN/d₁-Kombination
type depending on the SDR-class and on the combination of DN/d₁