

Vorschweißbund, kurz

- Eingeschränkte Druckbelastbarkeit gemäß DVS 2210-1 Beiblatt 3 Teil 2.1
- kurzes Schweißende

Stub end, short form

- limited pressure load acc. to DVS 2210-1 Supplement 3 Part 2.1
- short spigot end

VB - 2014 #1

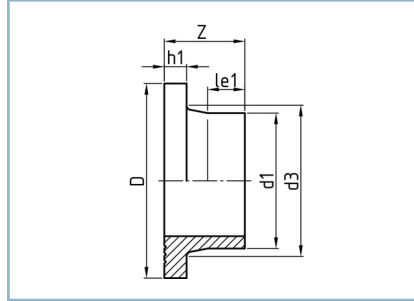

früher/former DIN 16962, 16963

DVGW:
DV-8606BT0423 (Ø 75 mm - Ø 225 mm),
DV-8611BT0424 (Ø 250 mm - Ø 630 mm)

Für PN 10 Losflansch.
Andere PN-Stufen auf Anfrage.
For PN 10 loose flange.
Other PN stages on request.

SDR	≥ 41	33	26	21	17,6	17	13,6	11	9	7,4	6	≤ 5
-----	------	----	----	----	------	----	------	----	---	-----	---	-----

d_1	d_3	l_{e1}	h_1	D	Z	Gewicht weight kg
50	61	23	12	88	50	0,1
63	75	16	14	102	50	0,1
75	89	14	16	122	50	0,2
90	105	43	17	138	80	0,3
110	125	37	18	158	80	0,3
125	132	42	18	158	80	0,3
140	155	34	18	188	80	0,5
160	175	34	18	212	80	0,6
180	180	30	20	212	80	0,6
200	232	36	24	268	100	1,4
225	235	46	24	268	100	1,2
250	285	35	25	320	100	2,0
280	291	45	25	320	100	1,8
315	335	35	25	370	100	2,5
355	373	50	30	430	120	3,9
400	427	42	33	482	120	5,2
450	514	14	46	585	120	10,1
500	530	24	46	585	120	8,6
560	615	10	50	685	120	13,3
630	642	30	50	685	120	10,6
710	737	20	50	800	120	15,5
800	840	18	52	905	120	20,5
900	944	15	55	1005	120	25,3
1000	1047	10	60	1110	140	35,4
1200	1245	30	90	1330	190	76,0

SDR	≥ 41	33	26	21	17,6	17	13,6	11	9	7,4	6	≤ 5
-----	------	----	----	----	------	----	------	----	---	-----	---	-----

1400	1425	27	70	1535	180	65,0
1600	1630	30	80	1760	200	97,0

Vorschweißbund, kurz

- Eingeschränkte Druckbelastbarkeit gemäß DVS 2210-1 Beiblatt 3 Teil 2.1
- kurzes Schweißende

Stub end, short form

- limited pressure load acc. to DVS 2210-1 Supplement 3 Part 2.1
- short spigot end

VB - 2019 #1

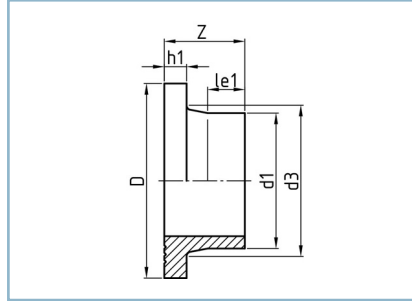

früher/former DIN 16962, 16963

DVGW:
DV-8606BT0423 (Ø 75 mm - Ø 225 mm)
DV-8611BT0424 (Ø 250 mm - Ø 630 mm)

Für PN 10 Losflansch.
Andere PN-Stufen auf Anfrage.
For PN 10 loose flange.
Other PN stages on request.

SDR ≥ 41 33 26 21 17,6 17 13,6 **11** 9 7,4 6 ≤ 5

d_1	d_3	l_{e1}	h_1	D	Z	Gewicht weight kg
20	27	30	7	45	50	0,01
25	33	28	9	58	50	0,02
32	40	27	10	68	50	0,04
40	50	24	11	78	50	0,1
50	61	23	12	88	50	0,1
63	75	16	14	102	50	0,1
75	89	14	16	122	50	0,2
90	105	43	17	138	80	0,3
110	125	37	18	158	80	0,4
125	132	35	25	158	80	0,5
140	155	27	25	188	80	0,7
160	175	27	25	212	80	0,9
180	180	20	30	212	80	0,9
200	232	28	32	268	100	2,0
225	235	38	32	268	100	1,8
250	285	25	35	320	100	2,9
280	291	35	35	320	100	2,6
315	335	25	35	370	100	3,6
355	373	40	40	430	120	5,7
400	427	29	46	482	120	7,6
450	514	10	60	585	130	14,2
500	530	10	60	585	120	12,2
560	615	10	60	685	130	18,5
630	642	20	60	685	120	15,3

WICHTIG - IMPORTANT

Für Druckanwendungen empfehlen wir unsere HP- und Sonderflansche (ab Seite 30).
Gern beraten wir Sie dazu.

For pressure applications HP and SF reduced flanges are recommended (from Page 30).
We will be pleased to advise you.

Vorschweißbund, lang

- Eingeschränkte Druckbelastbarkeit gemäß DVS 2210-1 Beiblatt 3 Teil 2.1
- langes Schweißende, für E-Muffen-Schweißung geeignet

Stub end, long form

- limited pressure load acc. to DVS 2210-1 Supplement 3 Part 2.1
- long welding end, for the use of electrofusion socket

VBL - 2019 #1

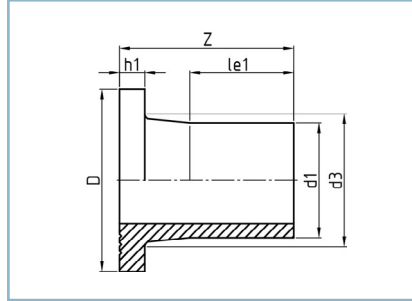

früher/former DIN 16962, 16963
ISO 9624

DVGW:
DV-8606BT0423 (Ø 75 mm - Ø 225 mm)
DV-8611BT0424 (Ø 250 mm - Ø 630 mm)

Für PN 10 Losflansch.
Andere PN-Stufen auf Anfrage.
For PN 10 loose flange.
Other PN stages on request.

SDR ≥ 41 33 26 21 **17,6** **17** 13,6 11 9 7,4 6 ≤ 5

d_1	d_3	l_{e1}	h_1	D	Z	Gewicht weight kg
63	75	81	14	102	115	0,2
75	89	89	16	122	125	0,2
90	105	103	17	138	140	0,3
110	125	117	18	158	160	0,5
125	132	132	18	158	170	0,6
140	155	154	18	188	200	0,9
160	175	154	18	212	200	1,1
180	180	150	20	212	200	1,2
200	232	136	24	268	200	2,1
225	235	146	24	268	200	2,1

In unserem Downloadportal auf www.reinert-ritz.de finden Sie unsere Broschüre zum Thema „Flanschverbindungen“ mit vielen hilfreichen Informationen.

In our download portal at www.reinert-ritz.de, you can find our brochure on „flanged connections“ with a lot of useful information.



Vorschweißbund, lang

- Eingeschränkte Druckbelastbarkeit gemäß DVS 2210-1 Beiblatt 3 Teil 2.1
- langes Schweißende, für E-Muffen-Schweißung geeignet

Stub end, long form

- limited pressure load acc. to DVS 2210-1 Supplement 3 Part 2.1
- long welding end, for the use of electrofusion socket

VBL - 2019 #1

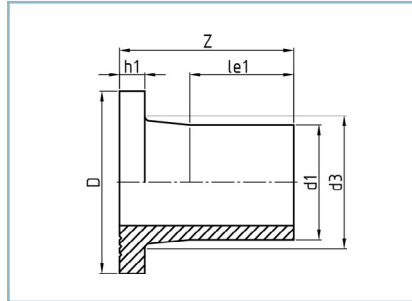

früher/former DIN 16962, 16963
ISO 9624

DVGW:
DV-8606BT0423 (Ø 75 mm - Ø 225 mm)
DV-8611BT0424 (Ø 250 mm - Ø 630 mm)

Für PN 10 Losflansch.
Andere PN-Stufen auf Anfrage.
For PN 10 loose flange.
Other PN stages on request.

SDR ≥ 41 33 26 21 17,6 17 13,6 **11** 9 7,4 6 ≤ 5

							Gewicht weight
d_1	d_3	l_{e1}	h_1	D	Z	kg	
50	61	73	12	88	100	0,1	
63	75	81	14	102	115	0,2	
75	89	89	16	122	125	0,3	
90	105	103	17	138	140	0,4	
110	125	117	18	158	160	0,7	
125	132	125	25	158	170	0,8	
140	155	147	25	188	200	1,3	
160	175	147	25	212	200	1,7	
180	180	140	30	212	200	1,9	
200	232	128	32	268	200	3,0	
225	235	138	32	268	200	3,1	

WICHTIG - IMPORTANT

Für Druckanwendungen empfehlen wir unsere HP- und Sonderflansche (ab Seite 30).
Gerne beraten wir Sie dazu.

For pressure applications HP and SF reduced flanges are recommended (from Page 30).
We will be pleased to advise you.