



QUICK-PIG PIGGING STATION

Operating Instructions

I CONTENTS

| | | |
|-----------|---|-------------------|
| 01 | BASIC INFORMATION | S. 04 - 05 |
| 02 | PIGGING WITH LINE MEDIUM | S. 06 - 09 |
| 03 | PIGGING WITH EXTERNAL MEDIUM | S. 10 - 11 |
| 04 | CATCHING THE PIG (FORWARD) | S. 12 - 17 |
| 05 | REVERSE PIGGING WITH EXTERNAL MEDIUM | S. 18 - 27 |
| 06 | INSERTION TOOL | S. 28 - 29 |
| 07 | LIFTING AID | S. 30 - 31 |



BASIC INFORMATION

CONVEYING DIRECTION

is the direction in which the media flow is pumped. **This may vary depending on the application.**

FLOW DIRECTION

is the direction in which the media flows during normal operation. **It is fixed and does not change.**



You can determine the flow direction using the arrow on the impact side of the dome after removing the cover.

SEALS

Before each insertion, the seals of the bayonet lock must be lubricated with sliding compound.

PIG TRAVEL TIME

Can be roughly estimated based on the flow speed and the length of the pigging section.

PIGGING DIRECTION INDICATOR

Available from size DN/OD 140 upwards. It indicates the direction of the pig within the sender/receiver.

For smaller sizes, the pigging direction can be determined by the shape of the flow channel underneath the flow direction indicator at the bayonet lock.

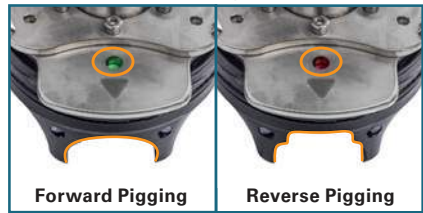

Green = Flow in the direction of media flow

Red = Flow opposite to media flow

Always ensure that the sender/receiver is correctly aligned with the bayonet lock before installation.

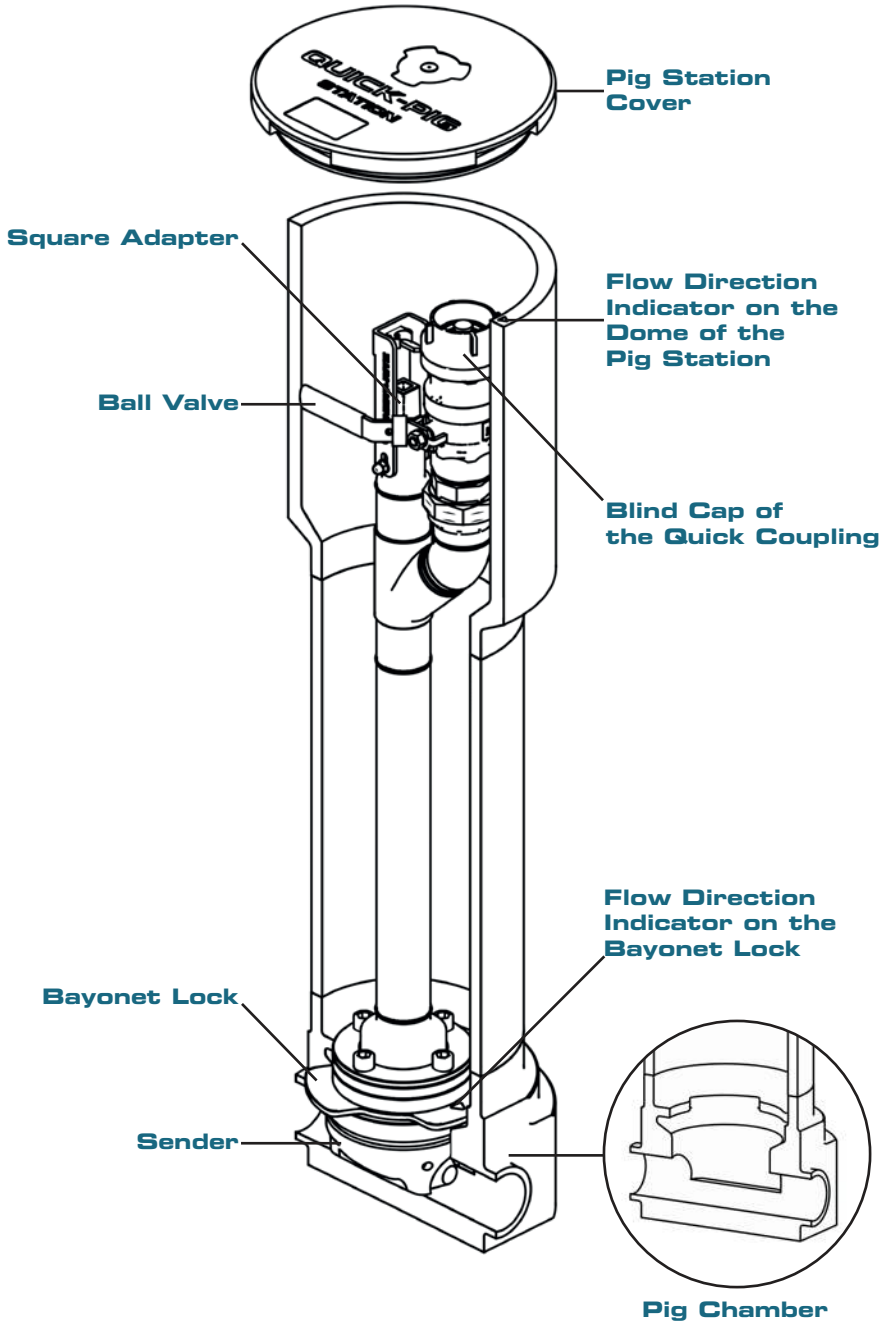

PIGGING WITH LINE MEDIUM

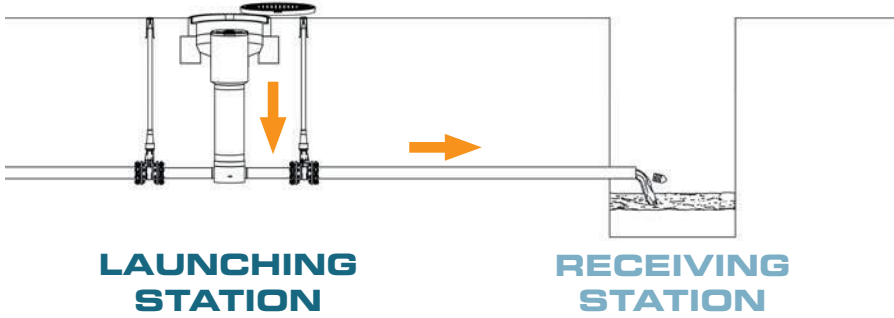

The receiving station can also be a second QUICK-PIG station.

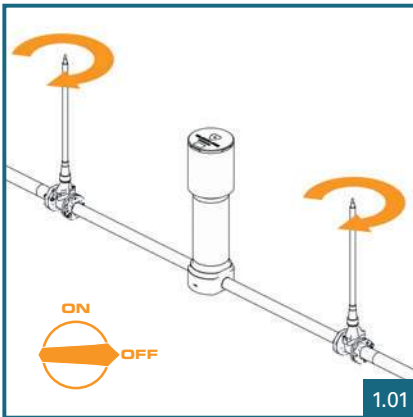

- Switch off pump.
- Close isolation valves before and after the pig station respectively.

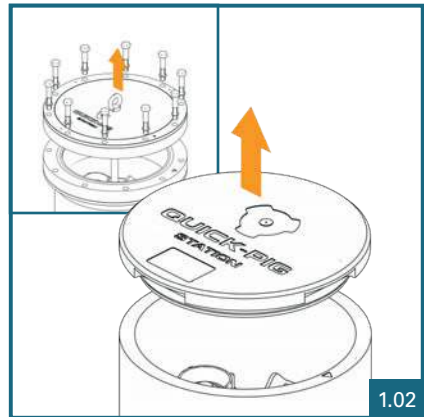

Remove the pigging station cover.

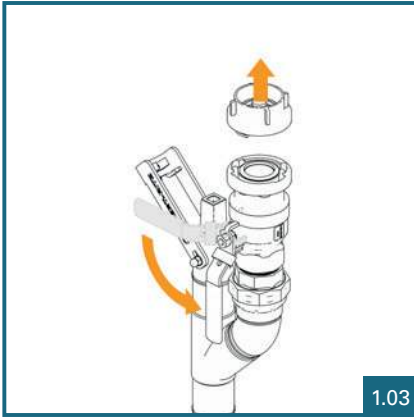

1.03

- Remove the blind cap of the quick coupling.
- Open the ball valve to relieve pressure.

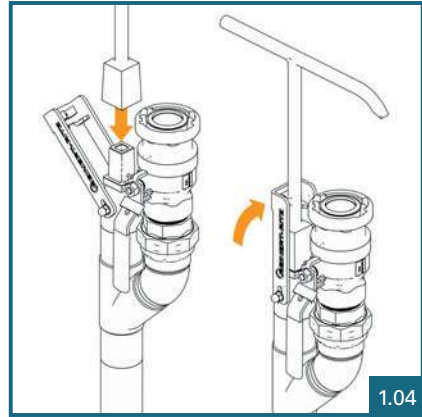

1.04

Insert hydrant key (C32) into the square adapter and lock it.

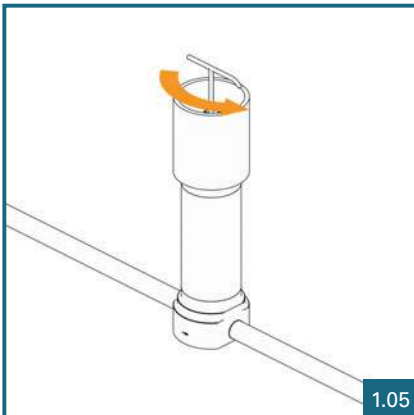

1.05

Turn the hydrant key counterclockwise until it stops.

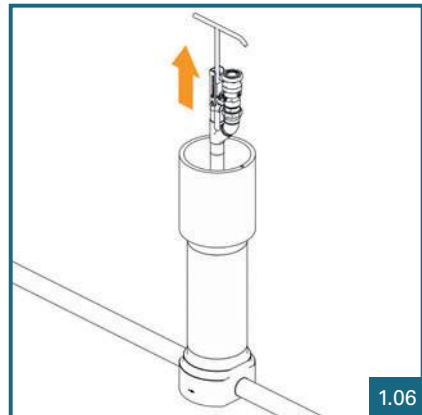

1.06

- Lift the bayonet lock with pig sender out of the station.
- Clean the pig chamber inside the pigging station.

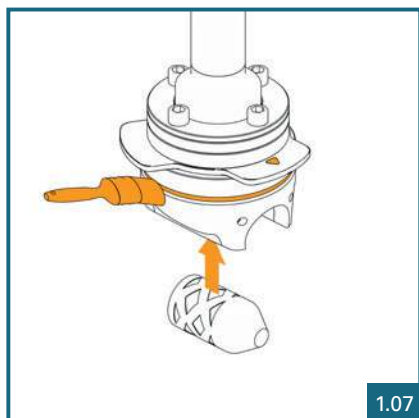

1.07

- Insert the pig in the conveying direction.
- Coat the seal on the bayonet lock with lubricant.

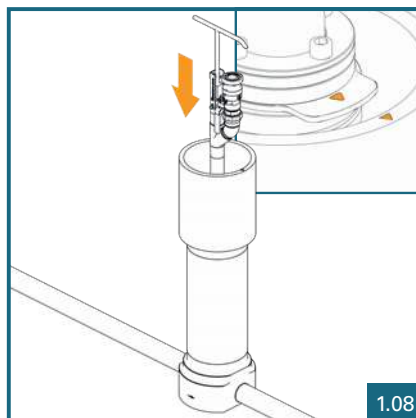

1.08

- Insert the bayonet lock with the pig sender into the pig station. (According to the flow direction, as indicated on the bayonet lock)
- Overcome the resistance of the seal with slight downward pressure. If necessary, use the insertion tool.

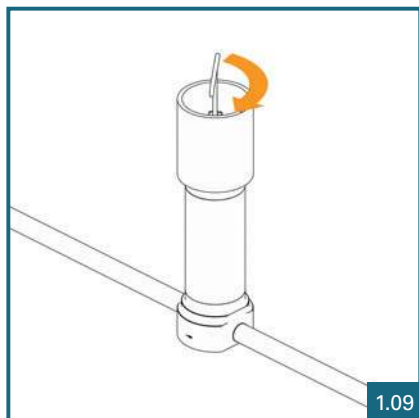

1.09

- Turn the hydrant key clockwise to the stop.
- Check the locking mechanism by pulling lightly upwards.

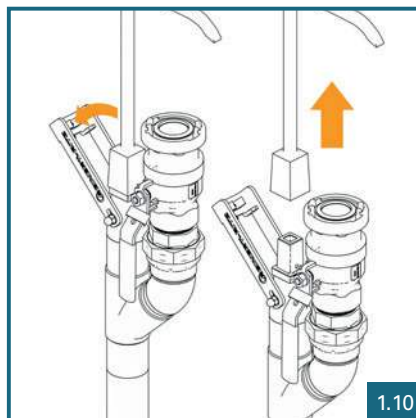

1.10

Unlock and remove the Hydrant Key C32.

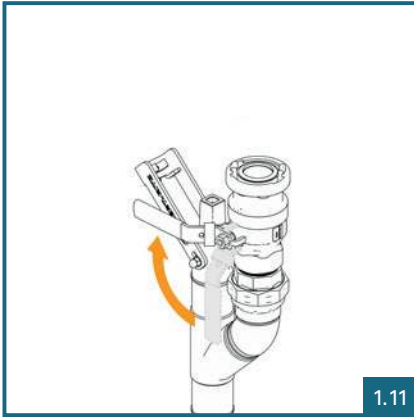

1.11

Close the ball valve.

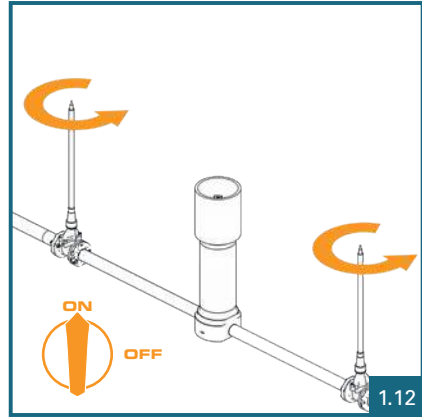

1.12

- Open all isolation valves.
- If applicable, prepare for pig catching (P. 12 - 17).
- Switch on pump: Pigging process begins.

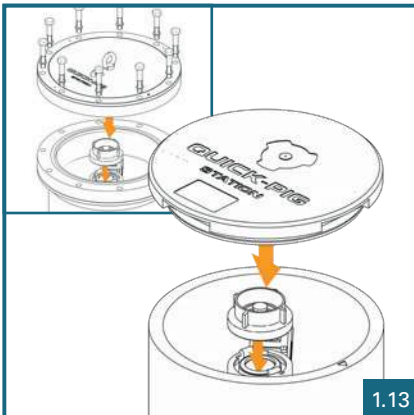

1.13

After launching the pig:

- Fit the blind cap onto the quick coupling.
- Replace the station cover.

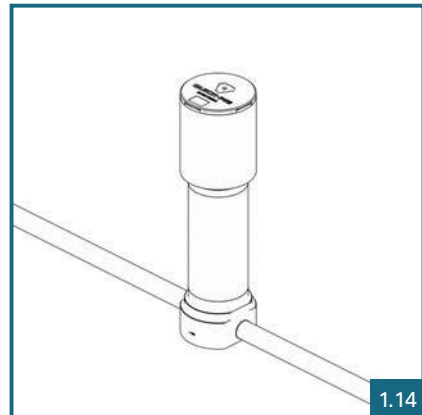

1.14

Station is returned to its original state.

PIGGING WITH EXTERNAL MEDIUM

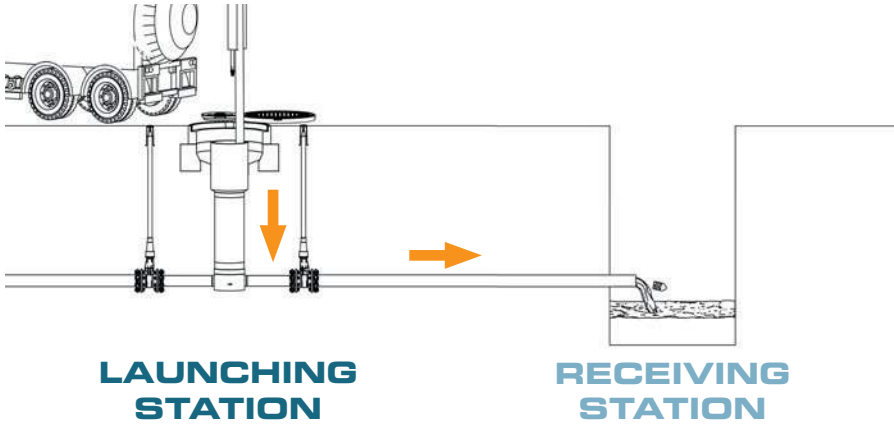

The receiving station can also be a second Quick-Pig Pig Station. (See P. 12)
In this case, the external medium can be discharged through the second Quick-Pig Pig Station.

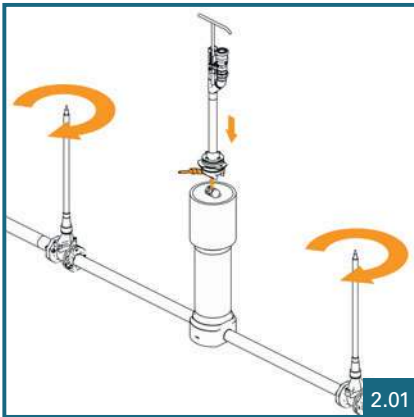

Perform steps 1.01 to 1.10, as described on pages 6-8.

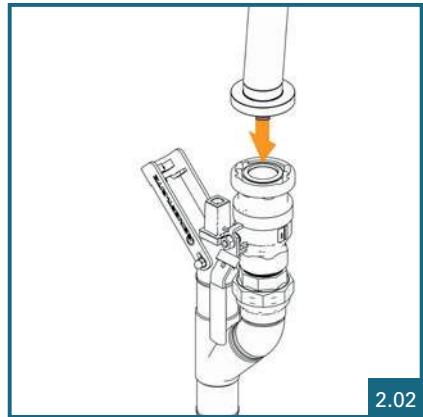

Connect the flushing hose to the quick coupling.

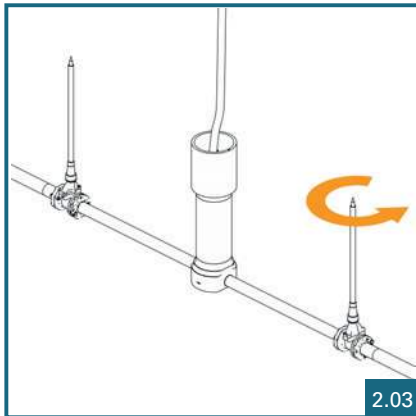

2.03

- Open the isolation valve in the flow direction.
- If applicable, prepare for pig catching. (P. 12 - 17)

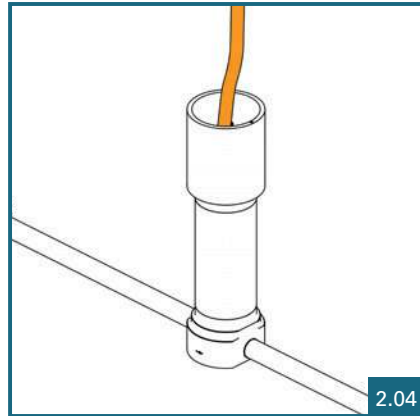

2.04

Inject external medium to start the pigging process.

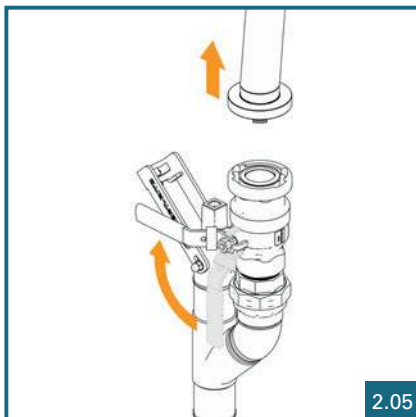

2.05

After completion of the pigging operations:

- Switch off the supply of the external medium.
- Close the ball valve.
- Remove the flushing hose.

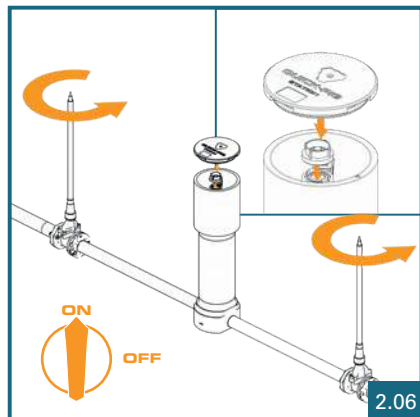

2.06

- Fit the blind cap onto the quick coupling.
- Replace the station cover.
- Open the isolation valve at the station inlet.
- Switch on pump.

■ CATCHING THE PIG (FORWARD)



LAUNCHING STATION

RECEIVING STATION

The line can be pigged sector by sector using one or more additional Quick-Pig stations.

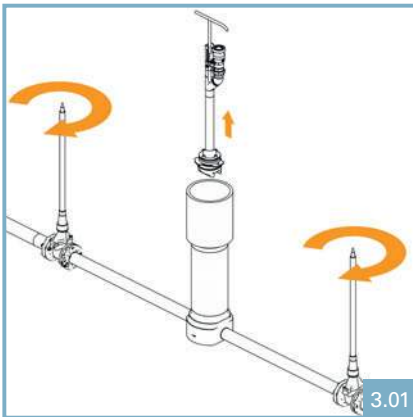

Perform steps 1.01 to 1.06, as described on pages 6-7, at the **receiving station**.



Swap the pig sender for the pig catcher.

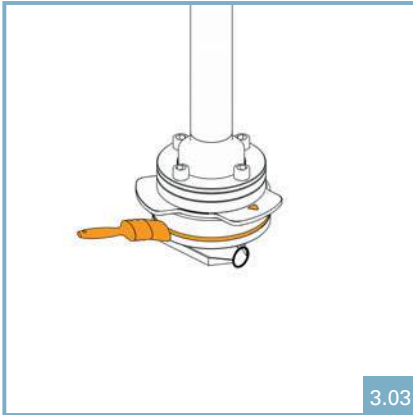

3.03

- Ensure that the catcher is aligned on the bayonet lock so that the pig direction indicator shows “green” (DN/OD ≥ 140). The “tip” of the catcher points in the flow direction.
- Coat the seal on the bayonet lock with lubricant.

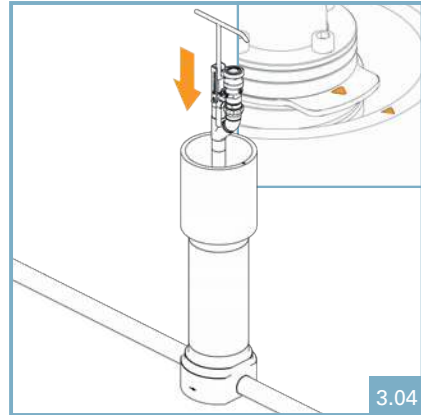

3.04

- Insert the bayonet lock with the pig catcher into the pig station. (According to the flow direction, as indicated on the bayonet lock)
- Overcome the resistance of the seal with slight downward pressure. If necessary, use the insertion tool.

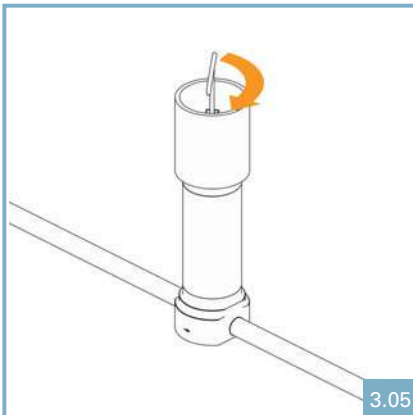

3.05

- Turn the hydrant key clockwise to the stop.
- Check the locking mechanism by pulling lightly upwards.

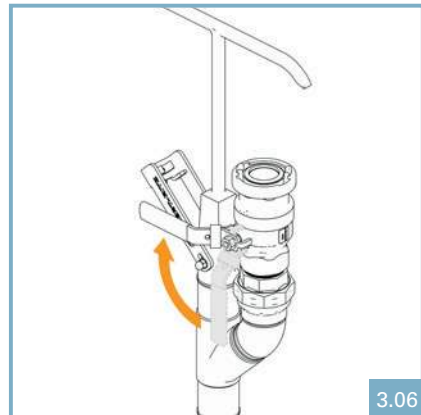

3.06

Close the ball valve.

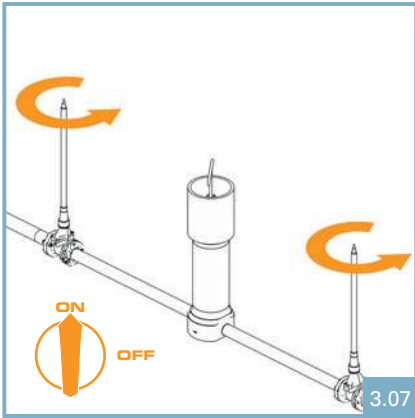

To start the pigging process:

- Open both isolation valves.
- Switch on pump.

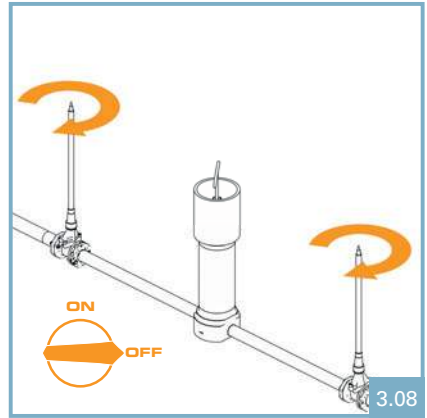

Once the pig has arrived:

- Switch off pump.
- Close both isolation valves.

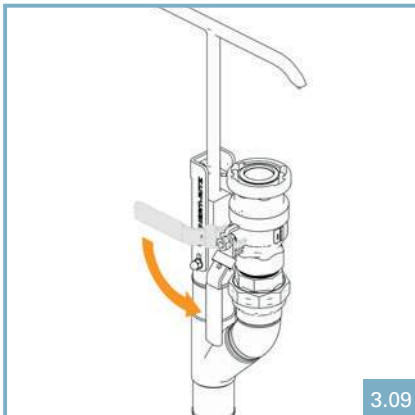

Open the ball valve for pressure relief.

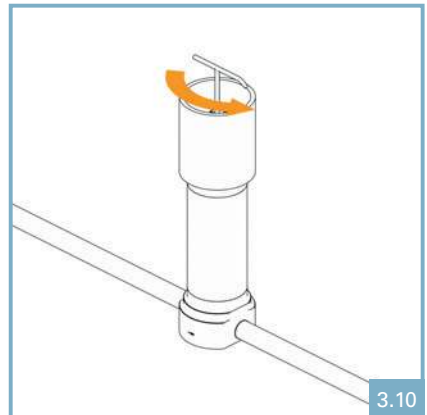

Turn the hydrant key counter-clockwise to the stop.

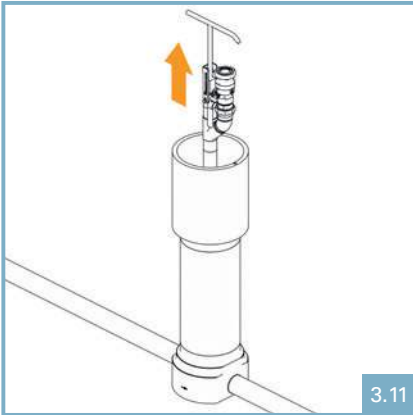

3.11

- Lift the bayonet lock with the pig catcher out of the pig station.
- Clean the pig chamber in the pig station.

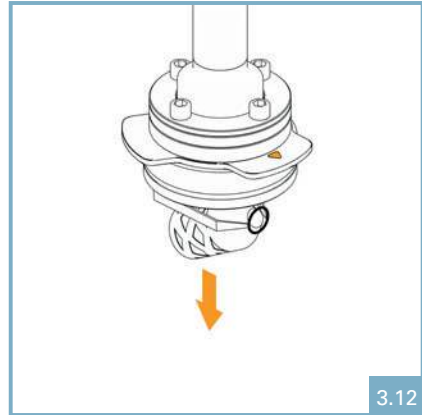

3.12

Remove the pig from the catcher.



3.13

Swap the pig catcher for the pig sender.

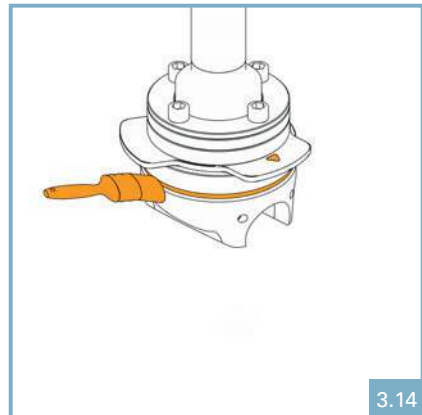

3.14

Coat the seal on the bayonet lock with lubricant.

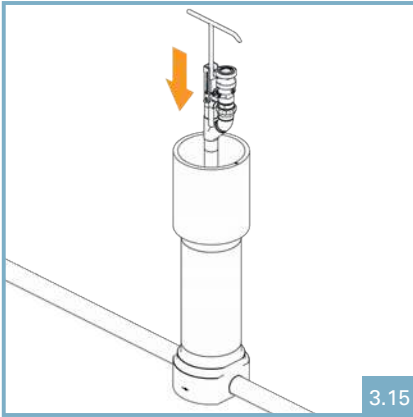

3.15

- Insert the bayonet lock with the pig sender into the pig station.
(According to the flow direction, as indicated on the bayonet lock)
- Overcome the resistance of the seal with slight downward pressure.
If necessary, use the insertion tool.

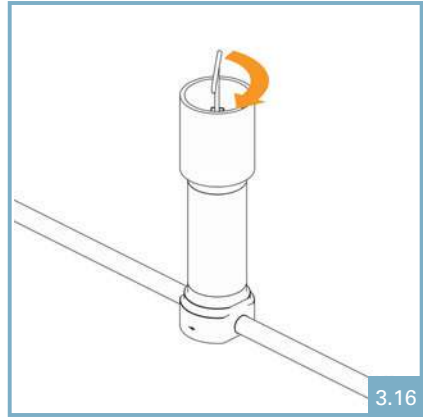

3.16

- Turn the hydrant key clockwise to the stop.
- Check the locking mechanism by pulling lightly upwards.

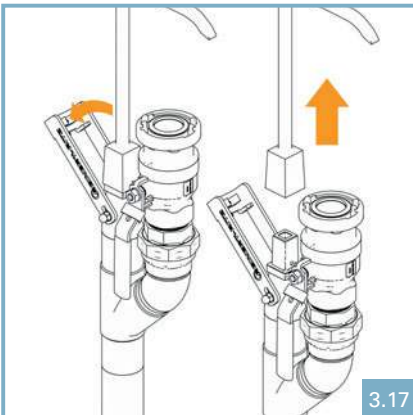

3.17

Unlock and remove the Hydrant Key C32.

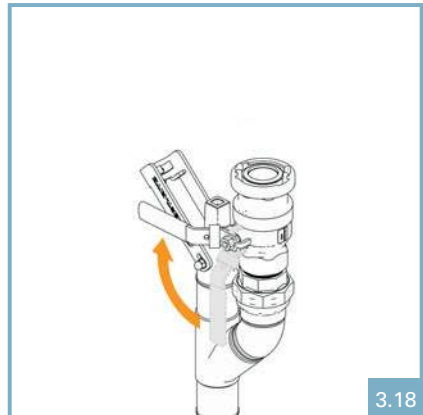

3.18

Close the ball valve.

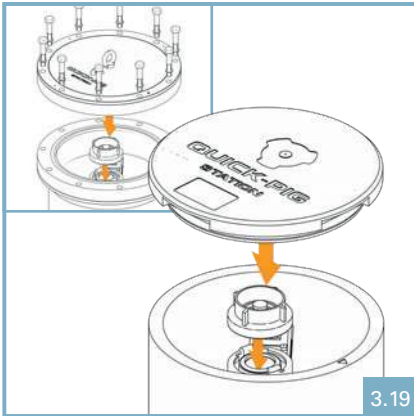

3.19

- Fit the blind cap onto the quick coupling.
- Replace the station cover.

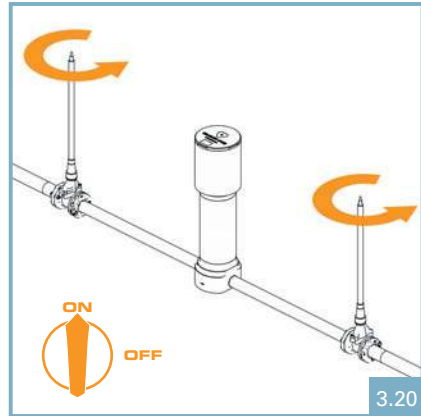

3.20

- Open all isolation valves.
- Switch on pump.

REVERSE PIGGING WITH EXTERNAL MEDIUM

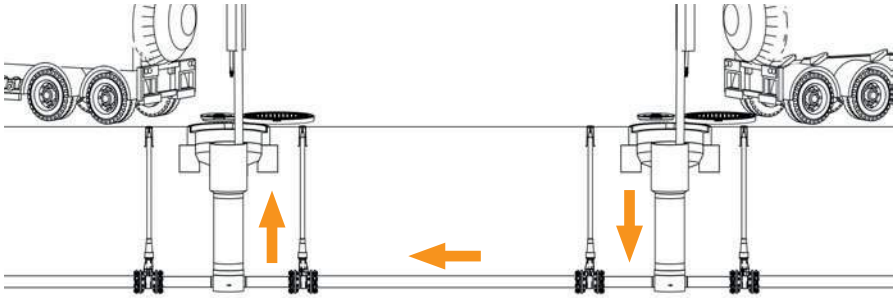

**LAUNCHING
STATION**

**RECEIVING
STATION**



NOTE

Reverse pigging is only possible on a line with more than one pig station.



PREPARATION OF THE LAUNCHING STATION

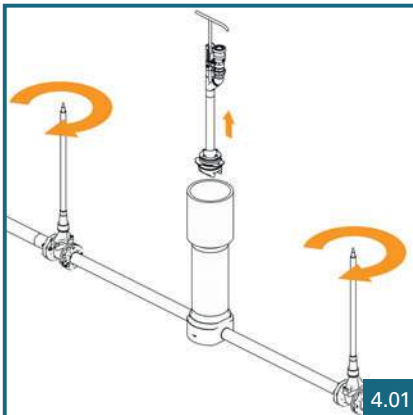

Perform steps 1.01 to 1.06, as described on pages 6-7.

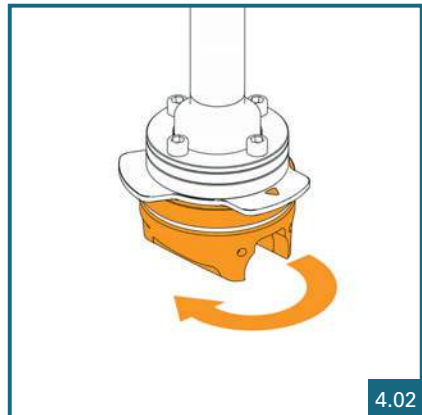

Rotate the sender on the bayonet lock by 180°, so that the flushing channel on the sender points in the direction of the arrow.

For sizes from DN/OD 140 upwards, the pig direction indicator shows „red“.

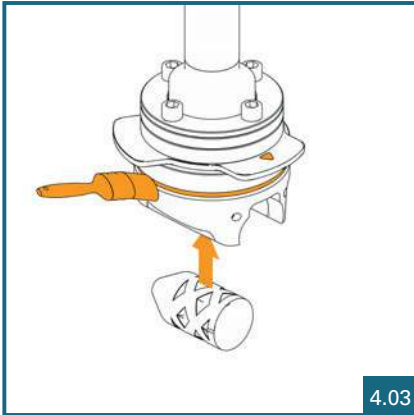

4.03

- Insert the pig in the conveying direction (which is now reversed relative to normal flow).
- Coat the seal on the bayonet lock with lubricant.

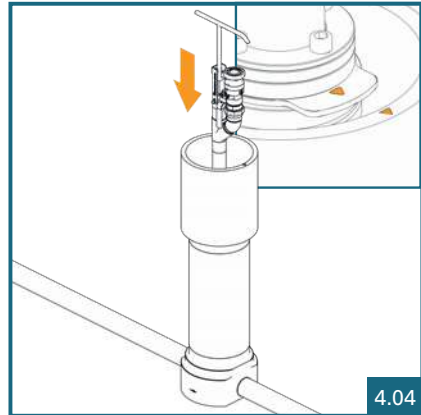

4.04

- Insert the bayonet lock with the pig sender into the pig station. (According to the normal flow direction indicator on the bayonet lock, even though pigging is reversed)
- Overcome the resistance of the seal with slight downward pressure. If necessary, use the insertion tool.

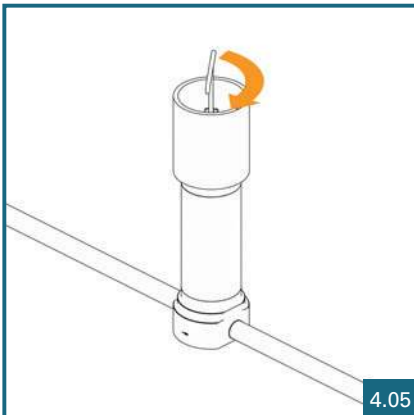

4.05

- Turn the hydrant key clockwise to the stop.
- Check the locking mechanism by pulling lightly upwards.

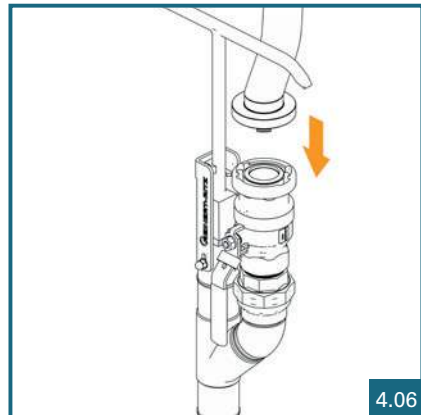

4.06

Connect the flushing hose (inlet for external medium) to the quick coupling.

PREPARATION OF THE RECEIVING STATION

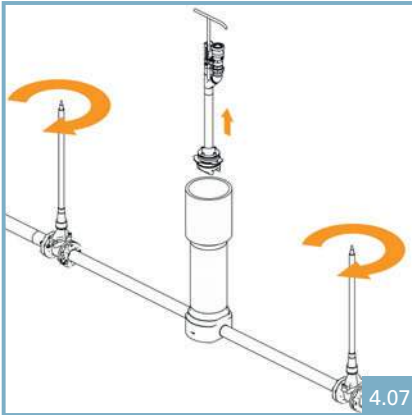

Perform steps 1.01 to 1.06, as described on pages 6-7.



- In the receiving station, swap the pig sender for the pig catcher.
- Open the ball valve.

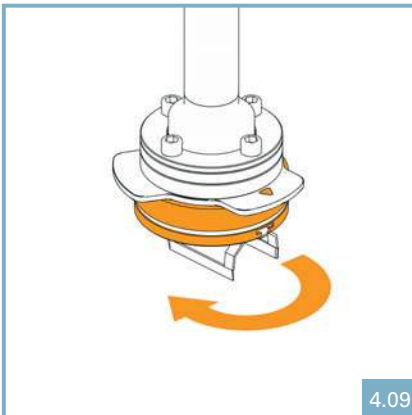

Rotate the pig catcher 180° before insertion. The catching basket points opposite to the normal flow direction. For sizes from DN/OD 140 upwards, the pig direction indicator on the bayonet lock shows „red“.

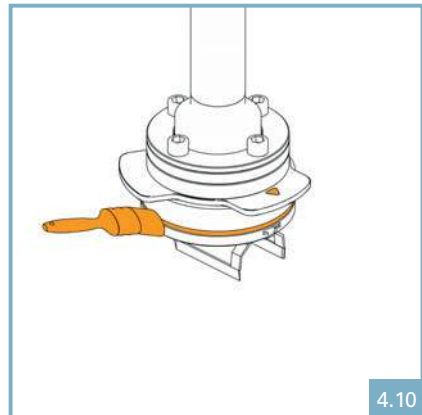

Coat the seal on the bayonet lock with the catcher with lubricant.

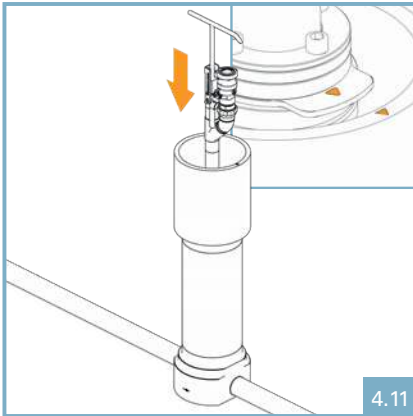

4.11

- Insert the bayonet lock with the pig catcher into the pig station. (According to the normal flow direction indicator on the bayonet lock)
- Overcome the resistance of the seal with slight downward pressure. If necessary, use the insertion tool.

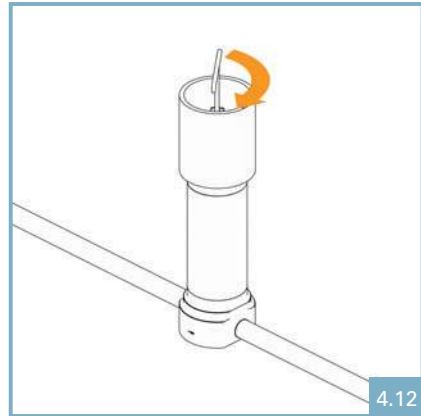

4.12

- Turn the hydrant key clockwise to the stop.
- Check the locking mechanism by pulling lightly upwards.

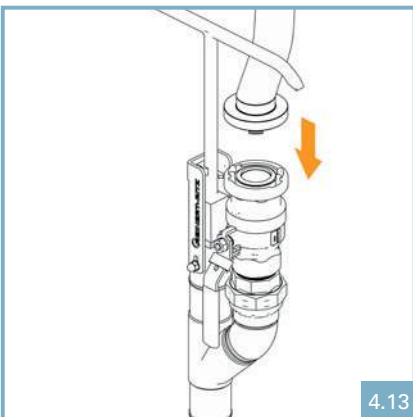

4.13

Connect the suction hose (outlet for external medium) to the quick coupling.

PERFORMING THE PIGGING PROCESS

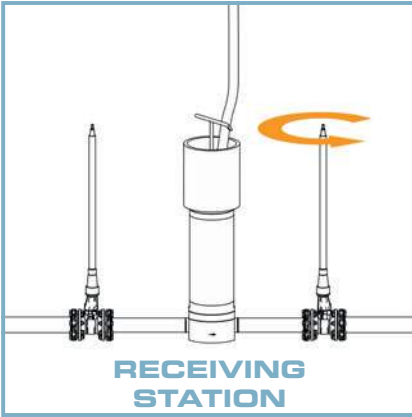

Open the isolation valve in the normal flow direction (this is the outlet during reverse pigging).

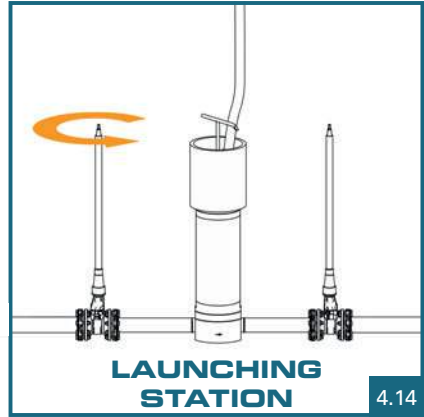

Open the isolation valve in the conveying direction (this is the inlet during reverse pigging).

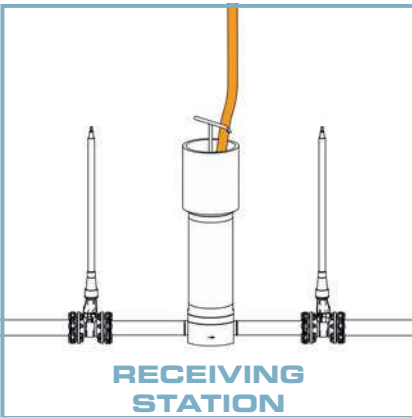

Discharge external medium.

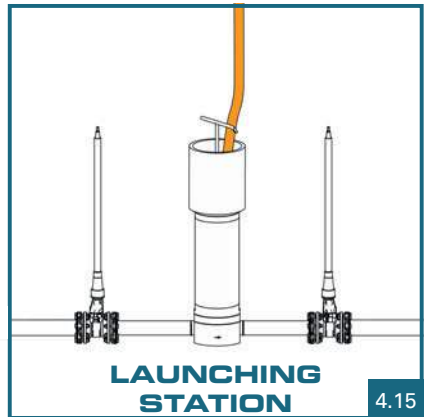

Inject external medium.

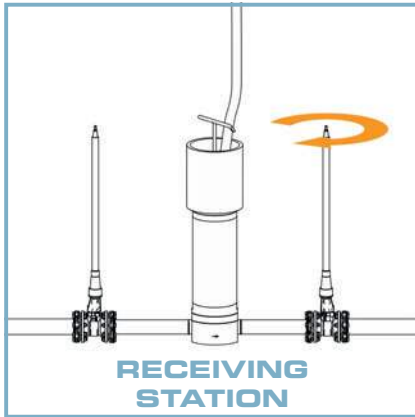

After arrival of the pig:

- Stop injecting external medium.
- Close the isolation valve in the normal flow direction.

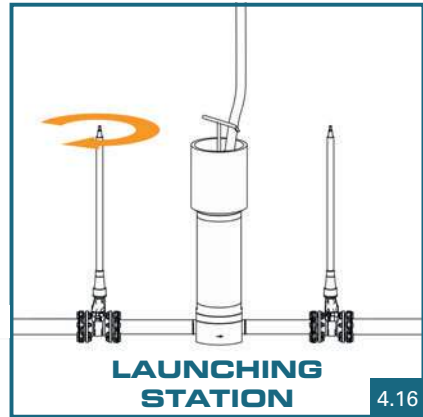

4.16

- Stop injecting external medium.
- Close the isolation valve in the conveying direction.

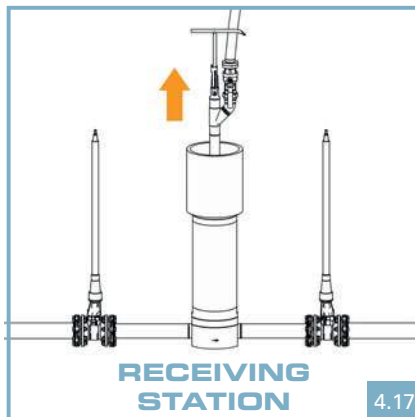

4.17

Unlock the bayonet lock with the pig catcher and lift it out of the pig station.

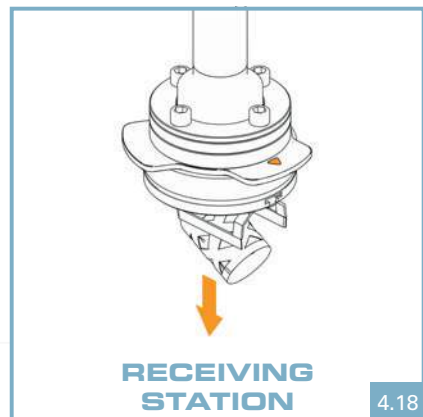

4.18

Remove the pig from the catcher.

POST-PROCESSING THE RECEIVING STATION

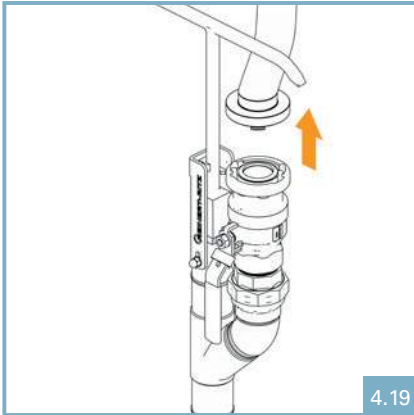

Remove the suction hose.



Rotate the pig catcher by 180° (back to normal forward catching orientation).



Swap the pig catcher for the pig sender.

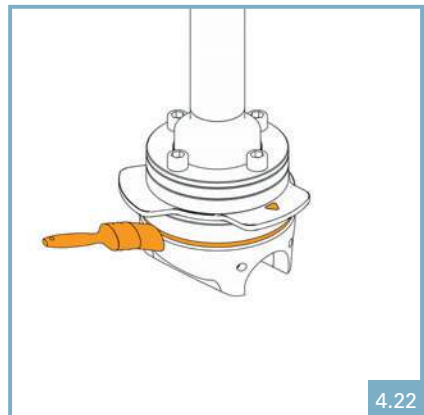

Coat the seal on the bayonet lock with lubricant.

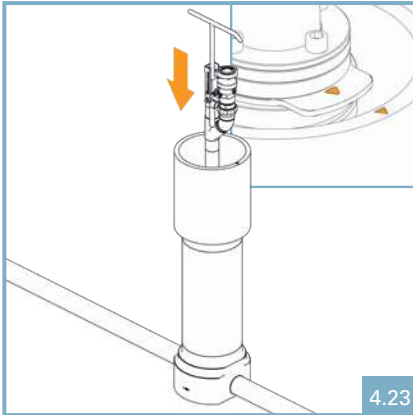

4.23

- Insert the bayonet lock with the pig sender into the pig station. (According to the normal flow direction, as indicated on the bayonet lock)
- Overcome the resistance of the seal with slight downward pressure. If necessary, use the insertion tool.

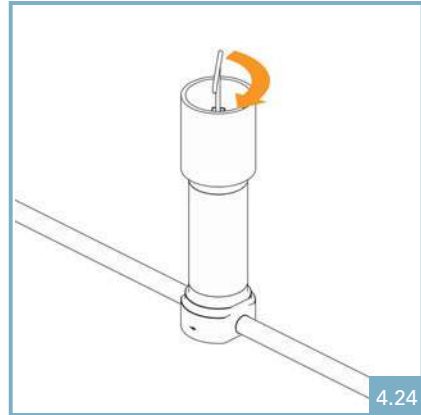

4.24

- Turn the hydrant key clockwise to the stop.
- Check the locking mechanism by pulling lightly upwards.

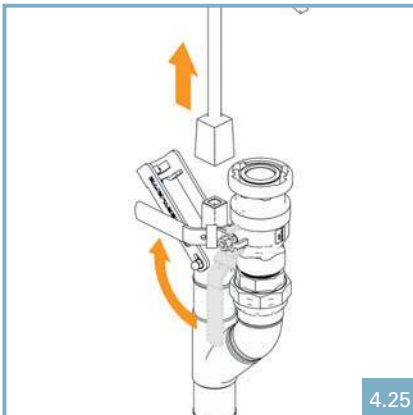

4.25

- Remove the hydrant key.
- Close the ball valve.

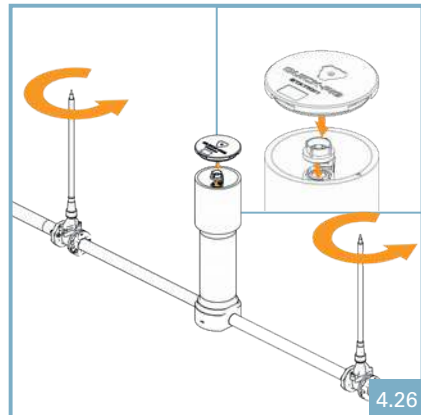

4.26

- Fit the blank cap onto the quick coupling.
- Replace the station cover.
- Open all isolation valves.
- Switch on pump.

POST-PROCESSING THE LAUNCHING STATION

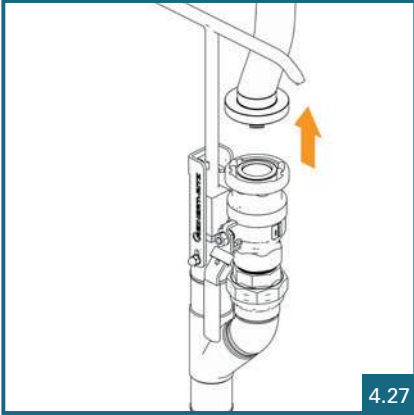

4.27

Remove the flushing hose.

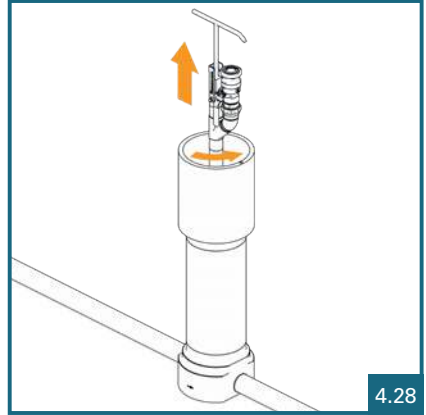

4.28

Unlock the bayonet lock with the pig sender and lift it out of the pig station.

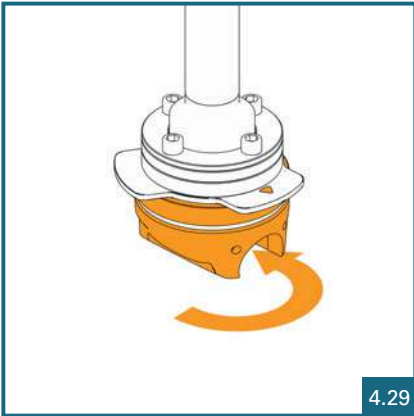

4.29

Rotate the pig sender by 180° (back to normal forward sending orientation).

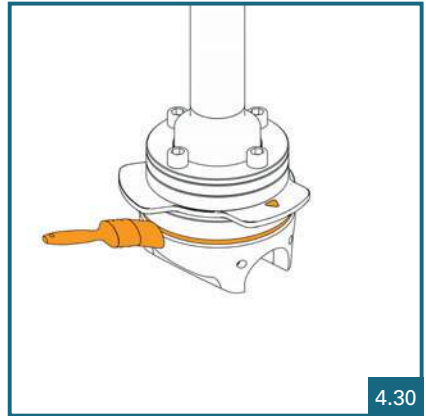

4.30

Coat the seal on the bayonet lock with lubricant.

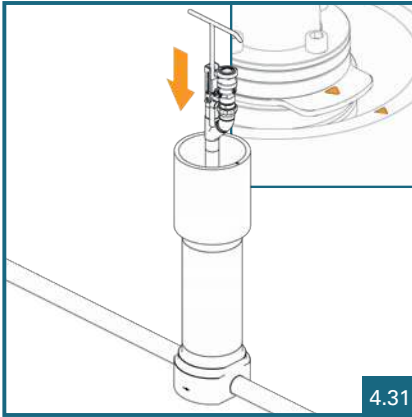

4.31

- Insert the bayonet lock with the pig sender into the pig station. (According to the normal flow direction, as indicated on the bayonet lock)
- Overcome the resistance of the seal with slight downward pressure. If necessary, use the insertion tool.

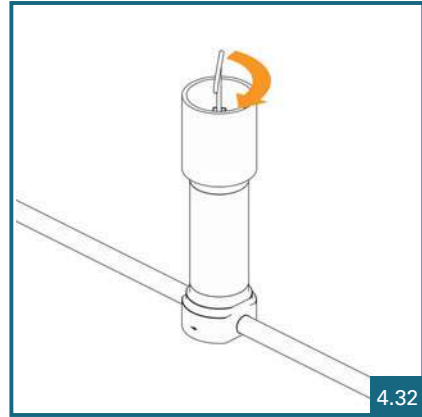

4.32

- Turn the hydrant key clockwise to the stop.
- Check the locking mechanism by pulling lightly upwards.

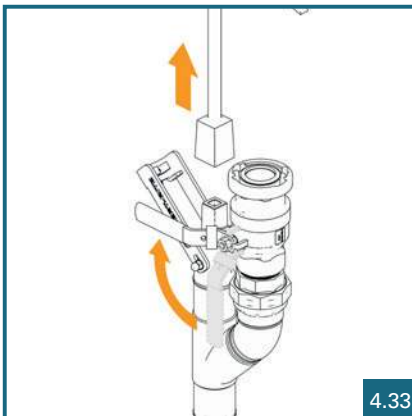

4.33

- Remove the hydrant key.
- Close the ball valve.

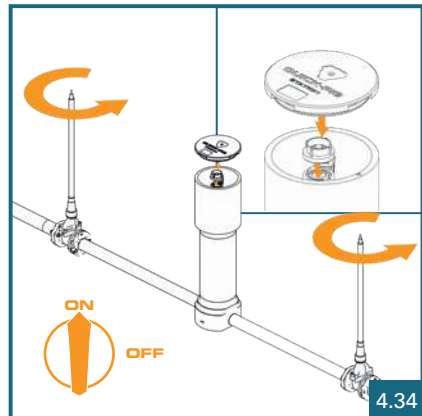

4.34

- Fit the blind cap onto the quick coupling.
- Replace the station cover.
- Open all isolation valves.
- Switch on pump.

■ INSERTION TOOL

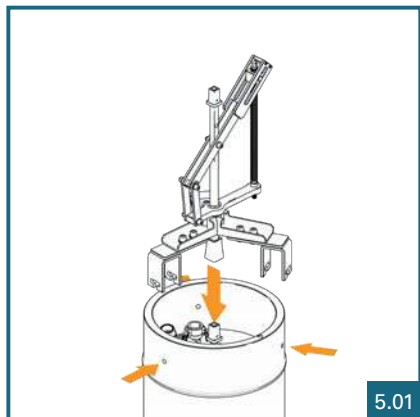

- Remove plugs from bolt holes.
- Check if the ball valve is open.
- Place the insertion tool onto the square connection of the pig insert in the pig station.



Fasten the insertion tool to the pig station with bolts.



Using a 16 mm wrench, turn the screw rod clockwise to press the bayonet lock downwards.



Place Hydrant Key C32 onto the square adapter.

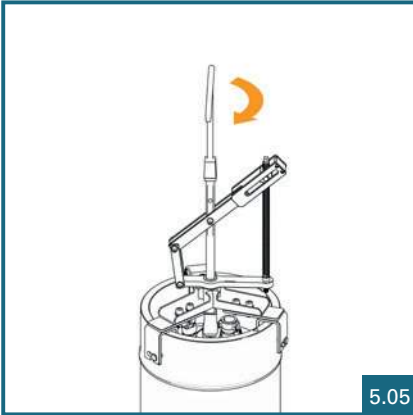

5.05

Turn the hydrant key clockwise to the stop.



5.06

- Remove bolts.
- Remove insertion tool.
- Re-insert plugs into bolt holes.
- Close the ball valve.



LIFTING AID

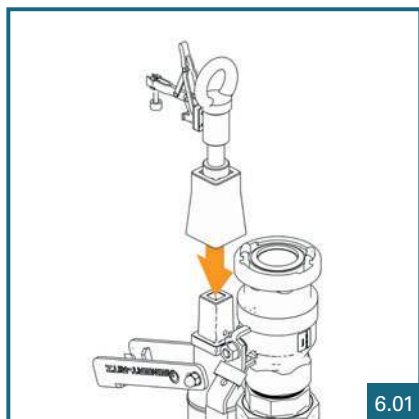

- Check that the bayonet lock is unlocked and the ball valve is open.
- Place the lifting aid onto the square adapter.



Fix the lifting aid using the locking mechanism.



Operate the lever of the lifting aid to secure the locking mechanism.



- Hook suitable lifting equipment into the lifting eye.
- Use the lifting equipment to pull the desired insert out of the station.





Reinert-Ritz GmbH
Ernst-Heinkel-Straße 2
D-48531 Nordhorn
Germany

Phone: +49 (0) 5921 8347-0
contact@reinert-ritz.com
www.reinert-ritz.de